

# MESSBOI 40 B LC / LC-MID

## Length measuring device with digital counter

Length measuring for various winding material

### MESSBOI 40 B LC / LC-MID

- Digital belt length measuring device for winding material-Ø max. 40 mm

#### Functionality:

This length measuring device is used for round and flat material such as cables, pipes, hoses, ropes of all kind. It is perfectly suited for high measurement precision and low measurement tolerances. The chassis consists of a stainless steel casing in which above all the sensitive components are well protected against outer influences. The scanning of the material to be measured is ensured by two measuring tape units running against each other. The top tape unit is liftable by means of a knee lever and due to its coordinated own weight adapts itself to the thickness of the material to be measured. For registration the length, the bottom measuring unit is provided with a rotary pulse encoder.

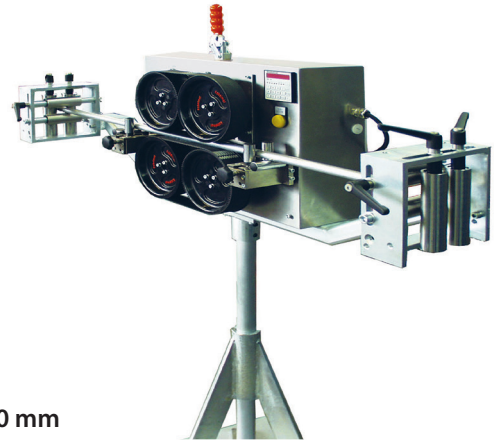

Fig. 1 MESSBOI 40 B LC with tripod stand

Technical data	MESSBOI 40 B LC / LC-MID
Part No.	0405.000
Round cable-Ø with MID / conformity assessment	1 - 40 mm
Tube-Ø with MID / conformity assessment	2 - 40 mm
Steel cable-Ø with MID / conformity assessment	2 - 15 mm
Thickness range flat cable with MID / conformity assessment	1 - 15 mm
Width range flat cable with MID / conformity assessment	10 - 40 mm
Speed conformity assessed	max. 250 m / min
Circumference of measuring wheel	0,5 m
Rotary pulse encoder	500 Imp / per turn 24 VDC
Error limit regarding accuracy class III with roller cages	+ /- 0,5 %
Display of counter	99999,999 m
L x W x H (without roller cages)	approx. 500 x 300 x 500 mm

#### Basic equipment:

- One set of inlet and outlet rollers with adjustable width
- Measuring tape with manual column-type measuring wheel adjustment
- Flange for a second rotary pulse encoder, provided for in the stainless steel casing
- Preselection counter and rotary pulse encoder integrated in the stainless steel casing
- A preselection counter LC MID with two potential-free electric contacts for controlling the fast motion / inching function of an adjustable winding drive. The counter is equipped with a plastic foil keyboard for inputting the data.
- Supervision of the calibrating speed with a luminous indicator

#### Supplementary equipment:

- **Tripod stand for floor mounting** (Height adjustable 1320 - 1620 mm) or **stand for table mounting**
- **Holding arm with inlet and outlet roller cage**
- **Manual height locking device of the measuring wheel**
- **Conformity assessment / MID (formerly first calibration)** of the length measuring device according module F with additional inlet and outlet roller cages is approved by German Authorities for a period of two years from date of delivery, valid for all EEA Member States. Conformity has to be carried out in the manufacturing firm. Prolongation of this approval after 2 years had expired is not included in the delivery
  - **Automatic storage** of the cutting data
  - **Label printer** with interface to the preselection counter
  - **Holder for label printer**

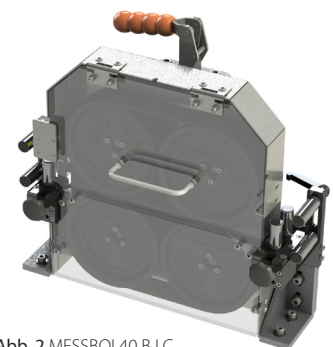

Abb. 2 MESSBOI 40 B LC